

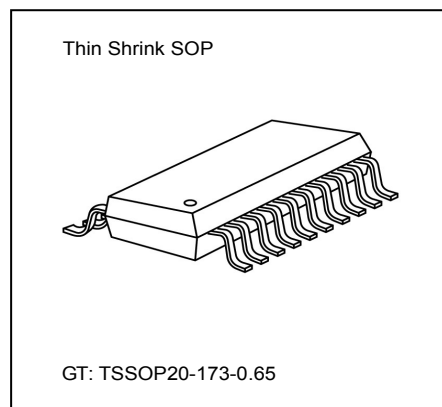

All-Ways-On™ Constant-Current LED Driver

Features

- 16 constant-current output channels
- Constant output current invariant to load voltage change
- Excellent output current accuracy:
between channels: <math><\pm 3\%</math> (max.), and
between ICs: <math><\pm 6\%</math> (max.)
- Output current adjusted through an external resistor
- Constant output current range per channel: 5-60 mA
- Schmitt trigger input
- 5V supply voltage
- Package Type: "Pb-free & Green" package with thermal pad



Current Accuracy		Conditions
Between Channels	Between ICs	
<math><\pm 3\%</math>	<math><\pm 6\%</math>	$I_{OUT} = 5 \sim 60 \text{ mA}$

Product Description

MBI1816 is an instant On/Off LED driver for lighting applications and exploits PrecisionDrive™ technology to enhance its output characteristics. At MBI1816 output stage, sixteen regulated current ports are designed to provide uniform and constant current sinks for driving LEDs within a large range of V_F variations.

MBI1816 provides users 16-channel constant current ports to match LEDs with equal current. Users may adjust the output current from 5 mA to 60 mA through an external resistor, R_{ext} , which gives users flexibility in controlling the light intensity of LEDs. In addition, users can precisely adjust LED brightness from 0% to 100% via output enable (\overline{OE}) with Pulse Width Modulation.

Additionally, to ensure the system reliability, MBI1816 is built with Thermal Protection (TP) function and thermal pad. The TP function protects IC from over temperature (165°C). Also, the thermal pad enhances the power dissipation. As a result, a large amount of current can be handled safely in one package.

Applications

- Automotive interior lighting
- Channel letter
- Decoration lighting

Typical Application Circuit

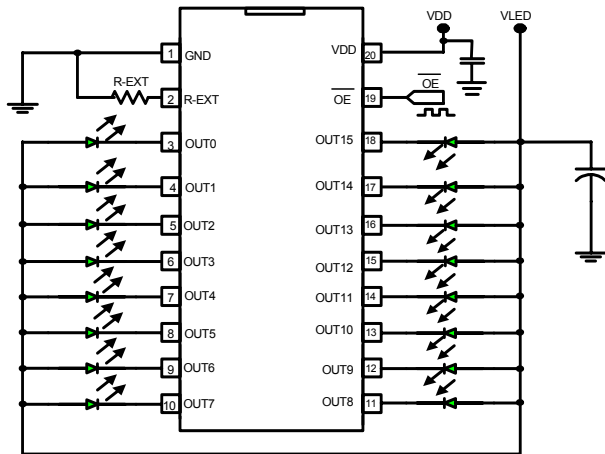
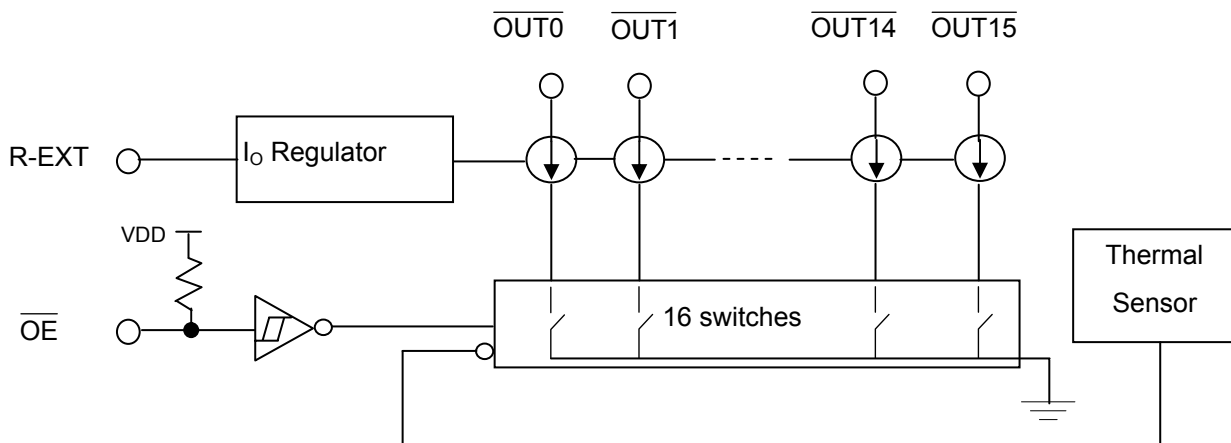
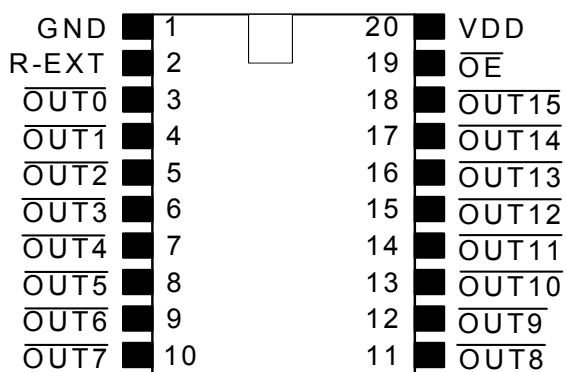

Figure 1

Functional Diagram



Pin Configuration



MBI1816GT

Pin Description

Pin Name	Function
GND	Ground terminal for control logic and current sink
OUT0~OUT15	Constant current output terminals
OE	Output enable terminal When OE is active (low), the output pins are enabled; when OE is inactive (high), all output pins are turned OFF (blanked).
R-EXT	Terminal used to connect an external resistor (R _{ext}) for setting up output current for all output channels
VDD	5V supply voltage terminal
Thermal Pad	Power dissipation terminals connected to GND*

*To eliminate the noise influence, the thermal pad is suggested to be connected to GND on PCB.

In addition, desired thermal conductivity will be improved, if a heat-conducting copper foil on PCB is soldered with thermal pad.

Maximum Ratings

Characteristic		Symbol	Rating	Unit
Supply Voltage		V_{DD}	0~7.0	V
Input Voltage		V_{IN}	-0.4~ $V_{DD} + 0.4$	V
Output Current		I_{OUT}	90*	mA
Sustaining Voltage		V_{DS}	-0.5~+17.0	V
GND Terminal Current		I_{GND}	1000	mA
Power Dissipation* (On PCB, $T_a=25^{\circ}C$)	TSSOP20	P_D	0.85	W
Thermal Resistance** (By simulation)		$R_{th(j-a)}$	31.99	$^{\circ}C/W$
Empirical Thermal Resistance* (On PCB, $T_a=25^{\circ}C$)			117	
Operating Junction Temperature		$T_{j,max}$	125	$^{\circ}C$
Operating Temperature		T_{opr}	-40~+85	$^{\circ}C$
Storage Temperature		T_{stg}	-55~+150	$^{\circ}C$

*Users must notice that the power dissipation (almost equaling to $I_{OUT} \times V_{DS}$) should be within the Safe Operation Area shown in Figure 7.

**Provided by factory.

Electrical Characteristics

Characteristic		Symbol	Condition	Min.	Typ.	Max.	Unit
Supply Voltage		V _{DD}	-	4.5	5.0	5.5	V
Sustaining Voltage at OUT pin		V _{DS}	$\overline{\text{OUT0}} \sim \overline{\text{OUT15}}$	-	-	17.0	V
Output Current		I _{OUT}	DC Test Circuit	5	-	60*	mA
Input Voltage	“H” level	V _{IH}	T _a = -40~85°C	0.7×V _{DD}	-	V _{DD}	V
	“L” level	V _{IL}	T _a = -40~85°C	GND	-	0.3×V _{DD}	V
Output Leakage Current		I _{OH}	V _{OH} = 17.0V	-	-	0.5	μA
Output Current 1		I _{OUT1}	V _{DS} = 0.6V R _{ext} = 2.4kΩ	-	30.5	-	mA
Current Skew 1		dI _{OUT} /I _{OUT}	I _{OL} = 30.5mA V _{DS} = 0.6V R _{ext} = 2.4kΩ	-	±1	±3	%
Output Current 2		I _{OUT2}	V _{DS} = 0.8V R _{ext} = 1.3kΩ	-	56	-	mA
Current Skew 2		dI _{OUT} /I _{OUT}	I _{OL} = 56mA V _{DS} = 0.8V R _{ext} = 1.3kΩ	-	±1	±3	%
Regulation of Output Current vs. Sustaining Voltage		%/dV _{DS}	V _{DS} within 1.0V and 3.0V	-	±0.1	-	% / V
Regulation of Output Current vs. Supply Voltage		%/dV _{DD}	V _{DD} within 4.5V and 5.5V	-	±1	-	% / V
Pull-up Resistor		R _{IN(up)}	$\overline{\text{OE}}$	250	500	800	KΩ
Junction Temperature Threshold		T _x	When T _j approaches T _x and $\overline{\text{OUT}}$ is shut off.	-	165	-	°C
Supply Current	“OFF”	I _{DD(off) 1}	R _{ext} = Open, $\overline{\text{OUT0}} \sim \overline{\text{OUT15}}$ = Off	-	5	9	mA
		I _{DD(off) 2}	R _{ext} = 2.4kΩ, $\overline{\text{OUT0}} \sim \overline{\text{OUT15}}$ = Off	-	6	10	
		I _{DD(off) 3}	R _{ext} = 1.3kΩ, $\overline{\text{OUT0}} \sim \overline{\text{OUT15}}$ = Off	-	8	12	
	“ON”	I _{DD(on) 1}	R _{ext} = 2.4kΩ, $\overline{\text{OUT0}} \sim \overline{\text{OUT15}}$ = On	-	6	10	
		I _{DD(on) 2}	R _{ext} = 1.3kΩ, $\overline{\text{OUT0}} \sim \overline{\text{OUT15}}$ = On	-	7	10	

* Each output current, I_{OUT}, can be driven up to 90mA, but the total output current should be smaller than 1A.

Test Circuit for Electrical Characteristics

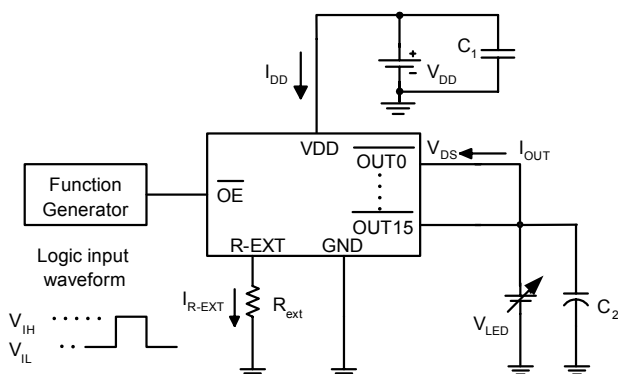

Figure 2

Switching Characteristics

Characteristic	Symbol	Condition	Min.	Typ.	Max.	Unit
Propagation Delay Time ("L" to "H")	$\overline{OE} - \overline{OUTn}$	$V_{DD} = 5.0\text{ V}$ $V_{DS} = 1.0\text{ V}$ $V_{IH} = V_{DD}$ $V_{IL} = \text{GND}$ $R_{ext} = 1229\Omega$ $(I_{OUTn} = 60\text{ mA})$ $V_L = 4.0\text{ V}$ $R_L = 44.62\ \Omega$ $C_L = 10\text{ pF}$	0.1	0.3	0.5	μs
Propagation Delay Time ("H" to "L")	$\overline{OE} - \overline{OUTn}$		0.05	0.1	0.2	μs
Pulse Width	\overline{OE}		1	-	-	μs
Output Rise Time of \overline{OUT} (turn off)	t_{or}		0.1	0.3	0.5	ns
Output Fall Time of \overline{OUT} (turn on)	t_{of}		0.1	0.3	0.5	ns

Test Circuit for Switching Characteristics

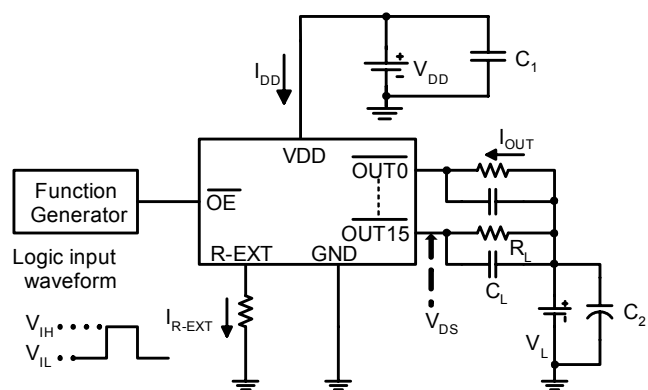
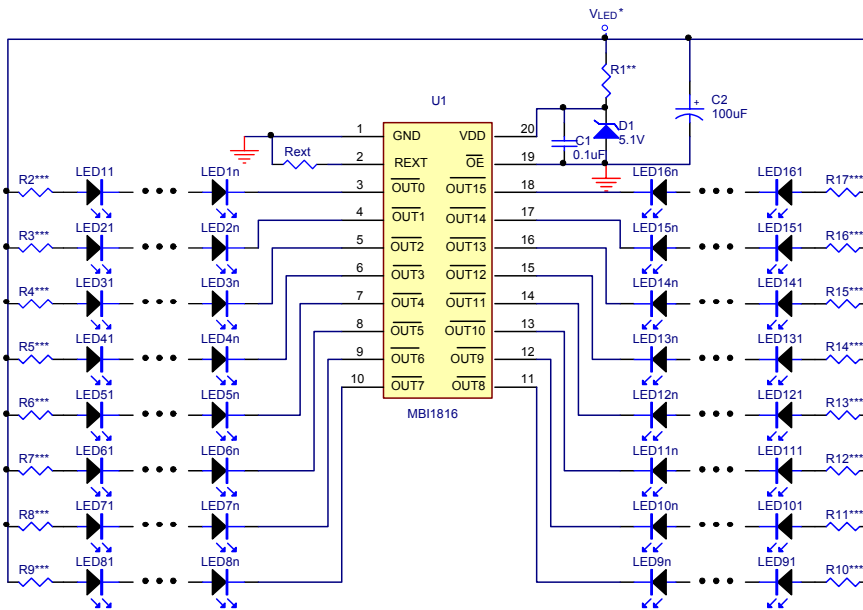

Figure 3

Application Circuits

(a) MBI1816 application circuit, where V_{LED} and V_{DD} share a single voltage source.



* $V_{LED} > V_{DS} + V_{F,LED} \times n$; $V_{F,LED}$: Forward voltage of LED; n: LED count

** $R1 = (V_{LED} - 5.1V) / I_{DD}$; refer to Electrical Characteristics for I_{DD}

*** $R2 \sim R17 = [V_{LED} - V_{DS} - (V_{F,LED} \times n)] / I_{LED}$

(b) MBI1816 application circuit with dimming control by PWM signal, where V_{LED} and V_{DD} use voltage sources separately.

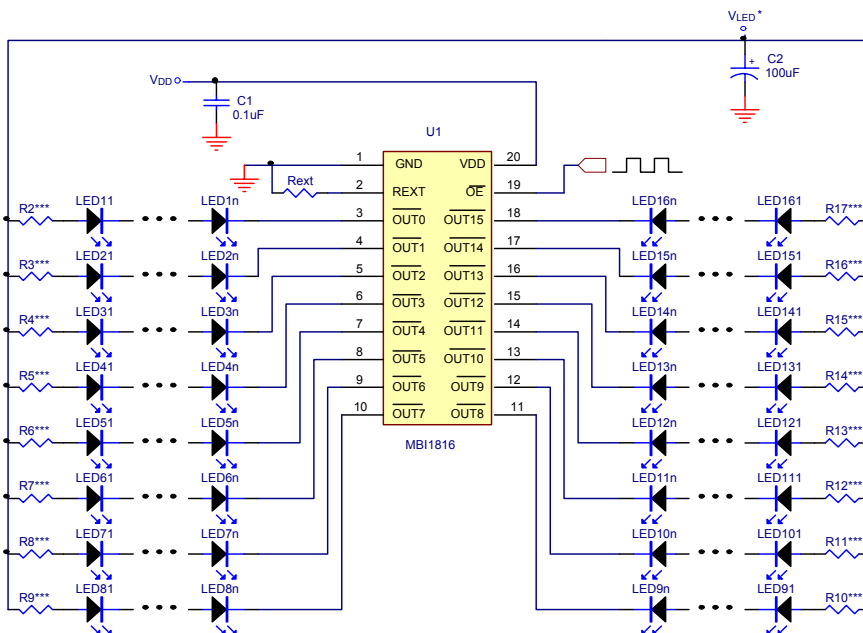

* $V_{LED} = V_{DS} + V_{F,LED} \times n$; $V_{F,LED}$: Forward voltage of LED; n: LED count

Figure 4

Constant Current

In LED lighting applications, MBI1816 provides nearly no variation in current from channel to channel and from IC to IC. This can be achieved by:

- 1) The maximum current variation between channels is less than $\pm 3\%$, and that between ICs is less than $\pm 6\%$.
- 2) In addition, the current characteristic of output stage is flat and users can refer to the figure as shown below. The output current can be kept constant regardless of the variations of LED forward voltages (V_F). This guarantees LED to be performed on the same brightness as user's specification.

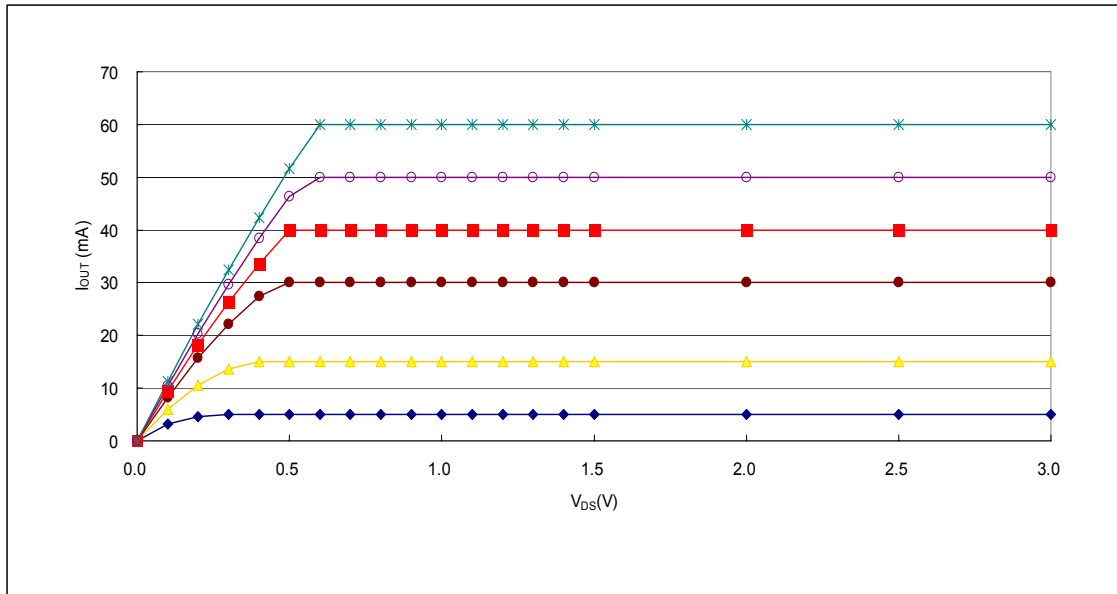

Figure 5

Setting Output Current

The output current of each channel (I_{OUT}) is set by an external resistor, R_{EXT} . The relationship between I_{OUT} and R_{EXT} is shown in the following figure.

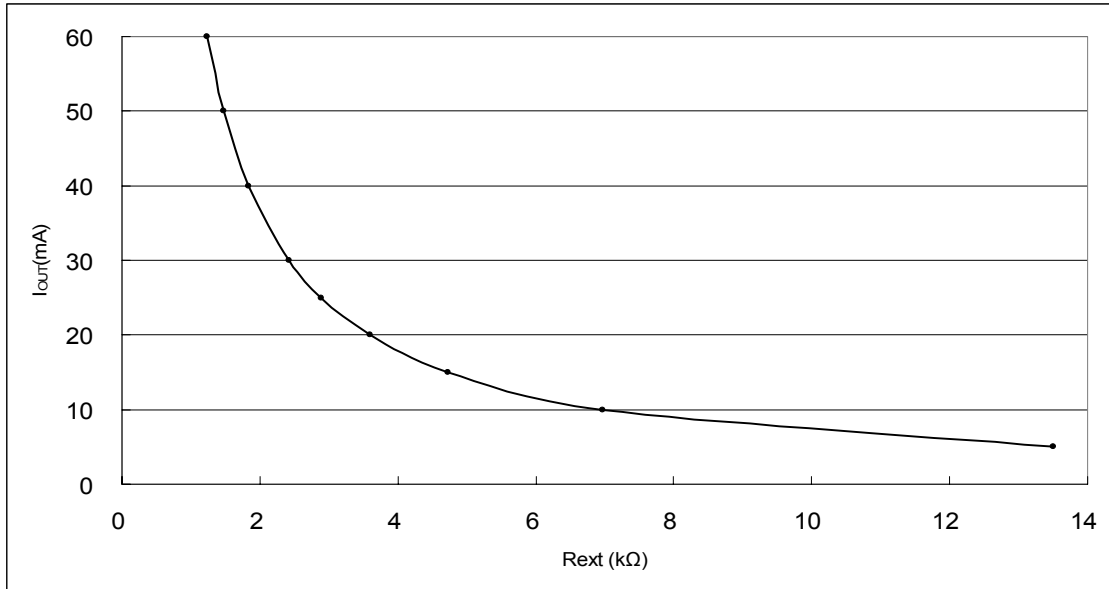

Figure 6

Also, the output current can be calculated from the equation:

$$V_{R-EXT} = 1.24V ;$$

$$R_{EXT} = (V_{R-EXT} / I_{OUT}) \times 59 = (1.24V / I_{OUT}) \times 59,$$

$$I_{OUT} = (V_{R-EXT} / R_{EXT}) \times 59 = (1.24V / R_{EXT}) \times 59 \text{ within } \pm 6\% \text{ chip skew}$$

where R_{EXT} is the resistance of the external resistor connected to R-EXT terminal and V_{R-EXT} is the voltage of R-EXT terminal. The magnitude of current (as a function of R_{EXT}) is around 56mA at 1.2kΩ and 30.5mA at 2.4kΩ.

Soldering Process of “Pb-free & Green” Package Plating*

Macroblock has defined "Pb-Free & Green" to mean semiconductor products that are compatible with the current RoHS requirements and selected **100% pure tin (Sn)** to provide forward and backward compatibility with both the current industry-standard SnPb-based soldering processes and higher-temperature Pb-free processes. Pure tin is widely accepted by customers and suppliers of electronic devices in Europe, Asia and the US as the lead-free surface finish of choice to replace tin-lead. Also, it is backward compatible to standard 215°C to 240°C reflow processes which adopt tin/lead (SnPb) solder paste. However, in the whole Pb-free soldering processes and materials, 100% pure tin (Sn) will all require up to 260°C for proper soldering on boards, referring to J-STD-020C as shown below.

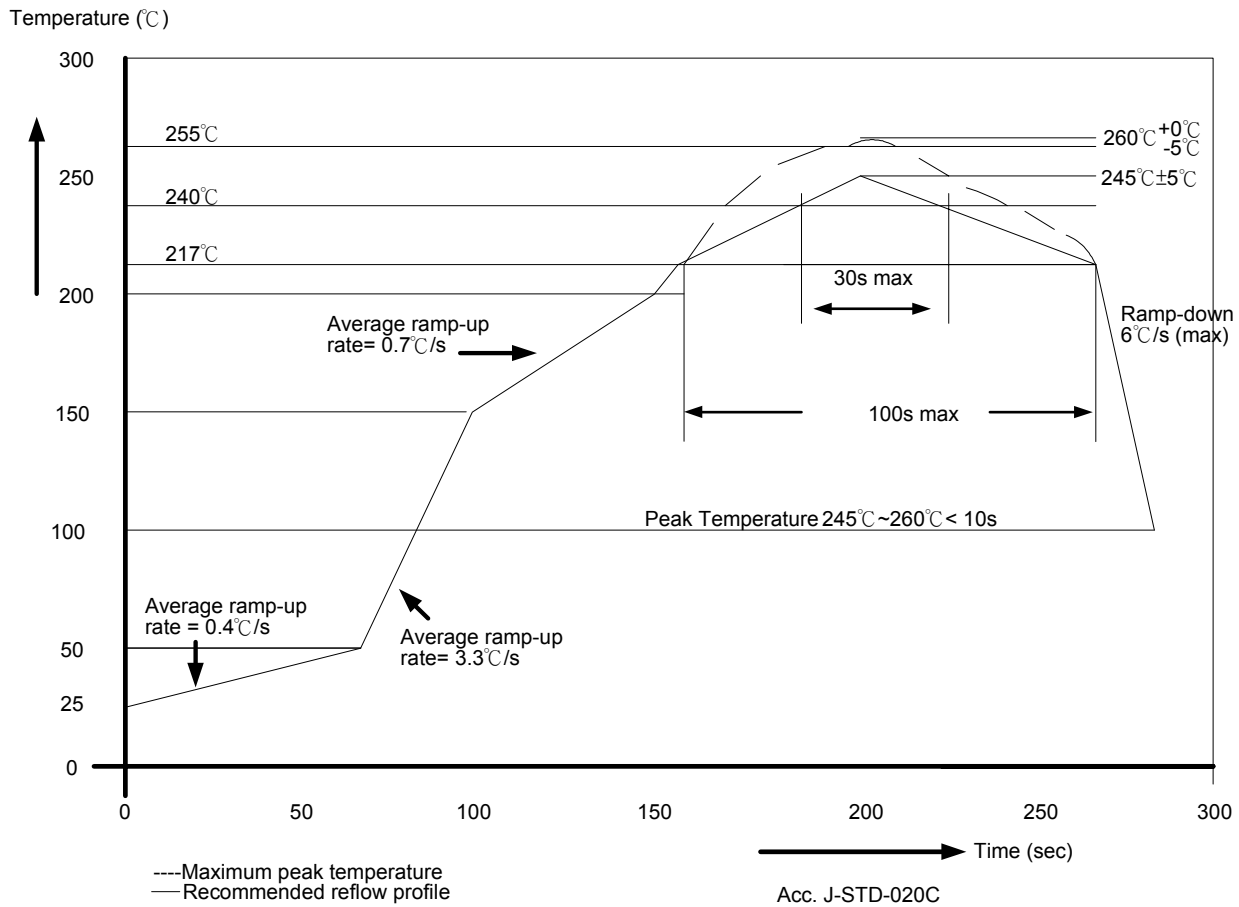

*Note: For details, please refer to Macroblock’s “Policy on Pb-free & Green Package”.

Package Power Dissipation (P_D)

The maximum power dissipation, $P_D(max) = (T_{j,max} - T_a) / R_{th(j-a)}$, decreases as the ambient temperature increases.

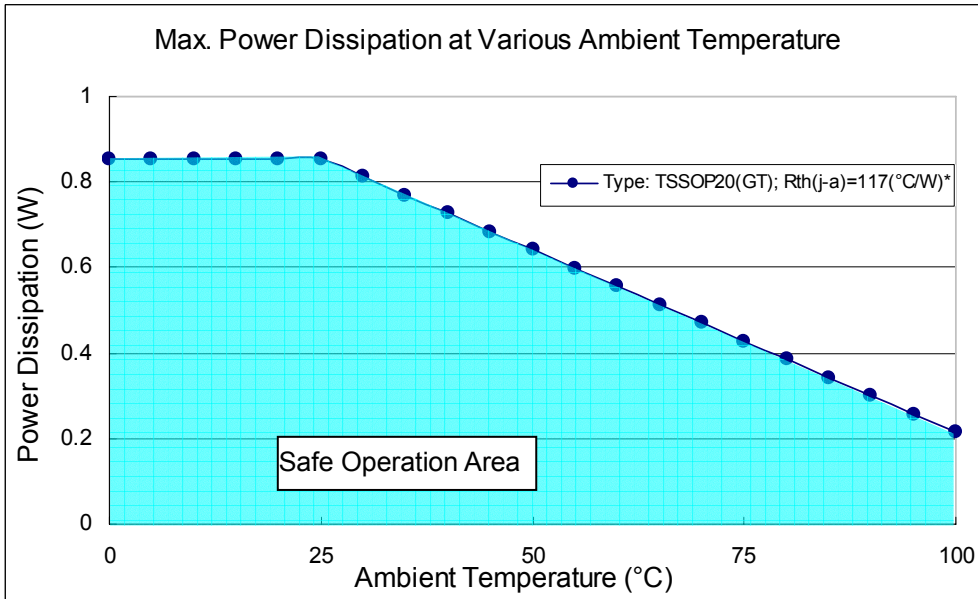

Figure 7

The maximum allowable package power dissipation is determined as $P_D(max) = (T_{j,max} - T_a) / R_{th(j-a)}$. When 16 output channels are turned on simultaneously, the actual package power dissipation is $P_D(act) = (I_{DD} \times V_{DD}) + (I_{OUT} \times Duty \times V_{DS} \times 16)$. Therefore, to keep $P_D(act) \leq P_D(max)$, the allowable maximum output current as a function of duty cycle is:

$$I_{OUT} = \{ [(T_j - T_a) / R_{th(j-a)}] - (I_{DD} \times V_{DD}) \} / V_{DS} / Duty / 16,$$

where $T_j = 125^\circ\text{C}$;

$$Duty = t_{ON} / T;$$

t_{ON} : the time of LEDs turning on; T : \overline{OE} signal period

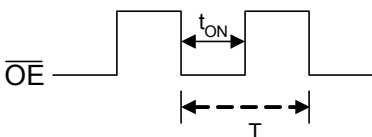

*Note: The empirical thermal resistor $R_{th(j-a)} = 117^\circ\text{C/W}$; it is based on the following structure.

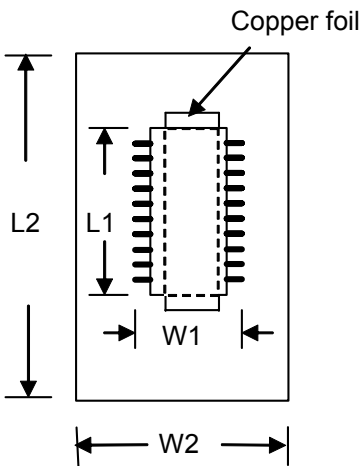

The PCB area $L2 \times W2$ is 4 times of the IC's area $L1 \times W1$.

The thickness of the PCB is 1.6 mm, copper foil 1 Oz. The thermal pad on the IC's bottom has to be mounted on the copper foil.

TP Function (Thermal Protection)

When the junction temperature exceeds the threshold, T_X (165°C), TP function turns off the output current. As soon as the temperature is below 165°C, the output current will be turned on again. The on-state and off-state switch at a high frequency; thus, the blinking is imperceptible. However, the average output current is limited, and therefore, the driver is protected from being overheated.

Load Supply Voltage (V_{LED})

MBI1816 is designed to operate with adequate V_{DS} to achieve constant current. V_{DS} together with I_{OUT} should not exceed the package power dissipation limit, $P_{D(max)}$.

As in Figure 8, $V_{DS} = V_{LED} - V_F$, and V_{LED} is the load supply voltage. $P_{D(act)}$ will be greater than $P_{D(max)}$, if V_{DS} drops too much voltage on the driver. In this case, it is recommended to use the lowest possible supply voltage or to set an external voltage reducer, V_{DROP} .

A voltage reducer lets $V_{DS} = (V_{LED} - V_F) - V_{DROP}$.

Resistors can be used in the applications as shown in Figure 8.

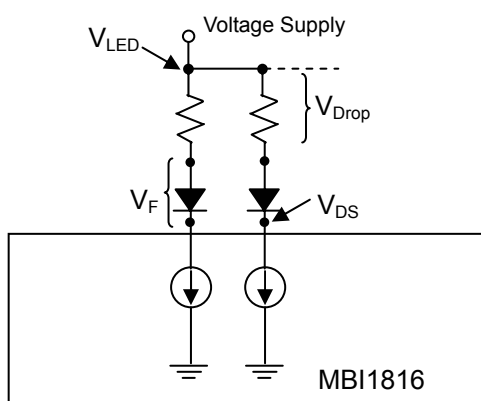
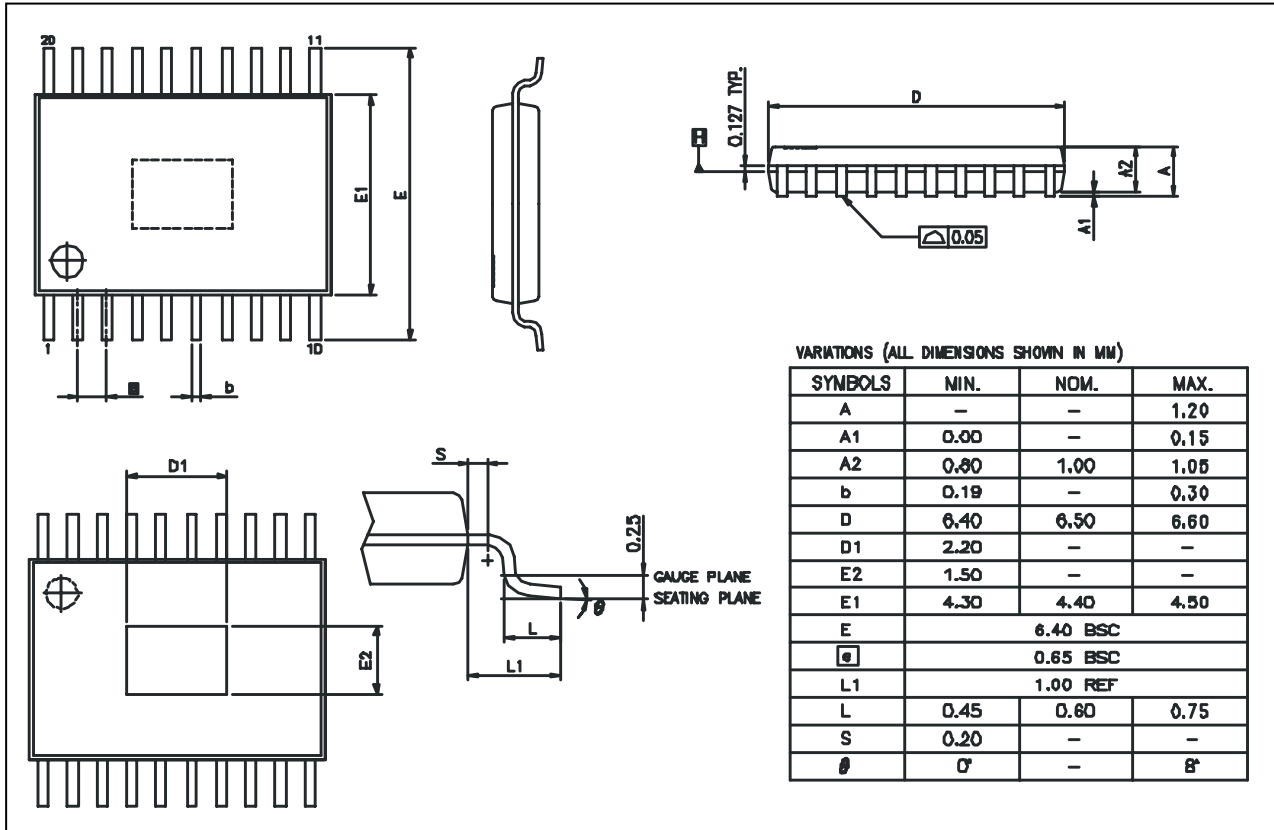

Figure 8

Outline Drawing



MBI1816GT Outline Drawing

Note: The unit for the outline drawing is mm.

Product Top-mark Information

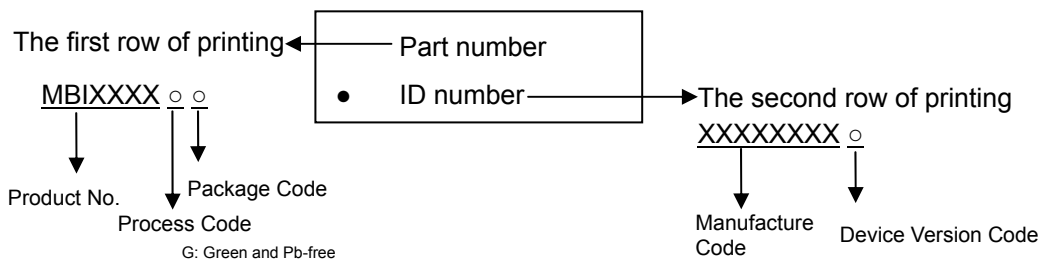

Product Revision History

Datasheet Version	Device Version Code
V1.00	Not defined
V1.01	A
V1.02	B
V1.03	B

Product Ordering Information

Part Number	Package Type	Weight (g)
MBI1816GT	TSSOP-173-0.65	0.0814

Disclaimer

Macroblock reserves the right to make changes, corrections, modifications, and improvements to their products and documents or discontinue any product or service without notice. Customers are advised to consult their sales representative for the latest product information before ordering. All products are sold subject to the terms and conditions supplied at the time of order acknowledgement, including those pertaining to warranty, patent infringement, and limitation of liability.

Macroblock's products are not designed to be used as components in device intended to support or sustain life or in military applications. Use of Macroblock's products in components intended for surgical implant into the body, or other applications in which failure of Macroblock's products could create a situation where personal death or injury may occur, is not authorized without the express written approval of the President of Macroblock. Macroblock will not be held liable for any damages or claims resulting from the use of its products in medical and military applications.

All text, images, logos and information contained on this document is the intellectual property of Macoblock. Unauthorized reproduction, duplication, extraction, use or disclosure of the above mentioned intellectual property will be deemed as infringement.