

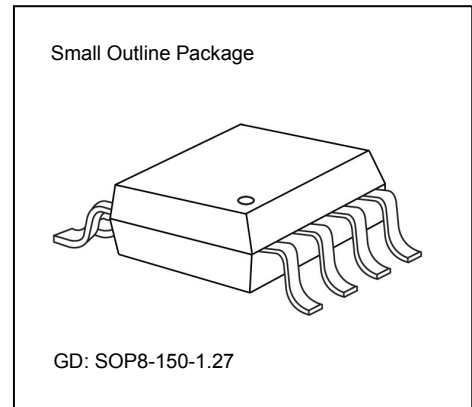

All-Ways-On™ High-Power LED Driver

Features

- 2 constant-current output channels
- Constant output current invariant to load voltage change
- Maximum output constant current per channel: 360 mA
- Thermal protection and flag
- Output current adjusted through an external resistor
- Schmitt trigger input
- 5V supply voltage
- Package type: “Pb-free & Green” package with thermal pad



Current Accuracy		Conditions
Between Channels	Between ICs	
< ±3%	< ±6%	$I_{OUT} = 40mA \sim 360 mA$ @ $V_{DS} = 0.6V$

Product Description

MBI1802 is an instant On/Off LED driver for high power LED applications and exploits PrecisionDrive™ and All-Ways-On™ technology to enhance its output characteristics.

With All-Ways-On™, MBI1802 provides users with 2-channel constant current ports. Users may adjust the output current up to 360 mA through an external resistor, R_{ext} , which gives users flexibility in controlling the light intensity of LEDs. Also, users can precisely adjust LED brightness from 0% to 100% via output control with Pulse Width Modulation. Alternatively, MBI1802 provides one-step current adjustment to make 25% of the output current via enabling the quarter pin (\overline{QT}) as “Low”.

Additionally, to ensure the system reliability, MBI1802 is built with Thermal Protection (TP) function and thermal pad. The TP function protects IC from over temperature (165°C). Also, the thermal pad enhances the power dissipation. As a result, a large amount of current can be sunk safely in one package.

Applications

- High-flux LED lighting
- Automotive interior lighting

Typical Application Circuit

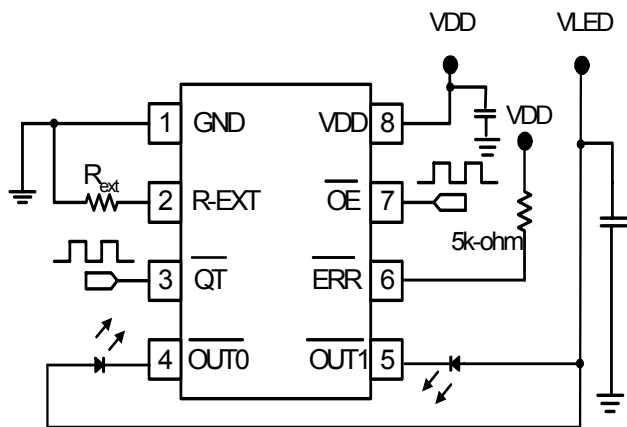
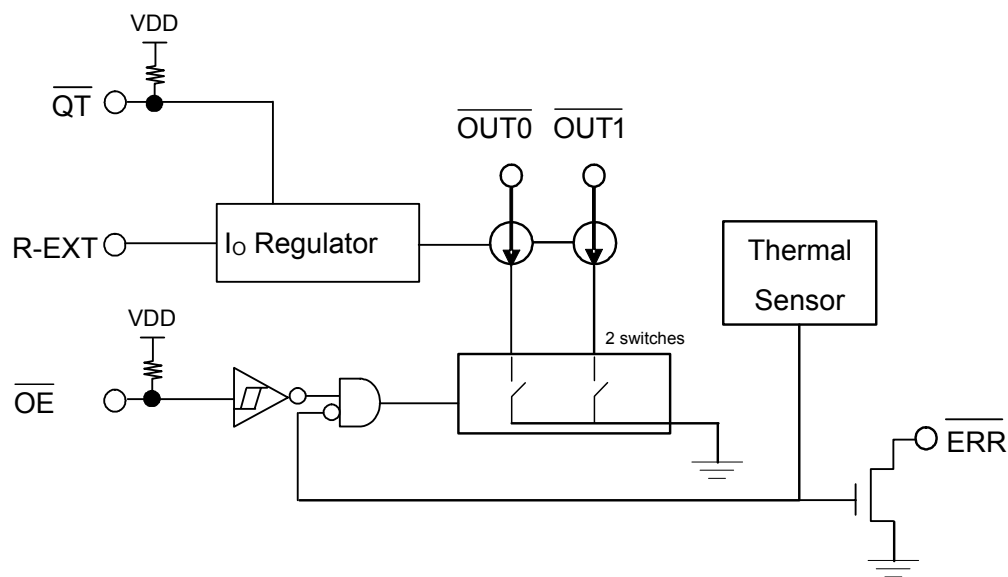
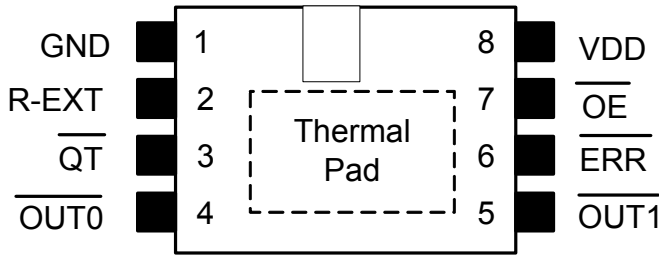

Figure 1

Functional Diagram



Pin Configuration



MBI1802GD

Pin Description

Pin No.	Pin Name	Function
1	GND	Ground terminal for control logic and current sink
2	R-EXT	Terminal used to connect an external resistor (R_{ext}) for setting up output current for all output channels
3	\overline{QT}	Set all the output current to 25% of the pre-set current when \overline{QT} is low. Default value is high.
4, 5	$\overline{OUT0} \sim \overline{OUT1}$	Constant current output terminals
6	\overline{ERR}	Open drain thermal error flag, when junction temperature is over 165°C, \overline{ERR} is going to low.
7	\overline{OE}	Output enable terminal When \overline{OE} is active (low), the output pins are enabled; when \overline{OE} is inactive (high), all output pins are turned OFF (blanked).
8	VDD	5V supply voltage terminal
-	Thermal Pad	Power dissipation terminals connected to GND*

*To eliminate the noise influence, the thermal pad is suggested to be connected to GND on PCB.

In addition, desired thermal conductivity will be improved, if a heat-conducting copper foil on PCB is soldered with thermal pad.

Maximum Ratings

Characteristic		Symbol	Rating	Unit
Supply Voltage		V_{DD}	0~7.0	V
Input Voltage		V_{IN}	-0.4~ $V_{DD} + 0.4$	V
Output Current		I_{OUT}	360*	mA
Sustaining Voltage		V_{DS}	-0.5~+17.0	V
GND Terminal Current		I_{GND}	720	mA
Power Dissipation* (On PCB, $T_a=25^{\circ}C$)	SOP8	P_D	0.8	W
Thermal Resistance** (By simulation)		$R_{th(j-a)}$	33.39	$^{\circ}C/W$
Empirical Thermal Resistance* (On PCB, $T_a=25^{\circ}C$)			125	
Operating Junction Temperature		$T_{j,max}$	125	$^{\circ}C$
Operating Temperature		T_{opr}	-40~+85	$^{\circ}C$
Storage Temperature		T_{stg}	-55~+150	$^{\circ}C$

*Users must notice that the power dissipation (almost equaling to $I_{OUT} \times V_{DS}$) should be within the Safe Operation Area shown in Figure 7.

** Provided by factory.

Electrical Characteristics

Characteristic		Symbol	Condition	Min.	Typ.	Max.	Unit
Supply Voltage		V_{DD}	-	4.5	5.0	5.5	V
Sustaining Voltage at \overline{OUT} pins		V_{DS}	$\overline{OUT0} \sim \overline{OUT1}$	-	-	17.0	V
Output Current		I_{OUT}	DC Test Circuit	40	-	360	mA
Input Voltage for $\overline{OE}, \overline{QT}$	“H” level	V_{IH}	$T_a = -40 \sim 85^\circ\text{C}$	$0.7 \times V_{DD}$	-	V_{DD}	V
	“L” level	V_{IL}	$T_a = -40 \sim 85^\circ\text{C}$	GND	-	$0.3 \times V_{DD}$	V
Output Leakage Current		I_{OH}	$V_{OH} = 17.0\text{V}$	-	-	0.5	μA
\overline{ERR} Output Voltage		V_{OL}	$I_{OL} = +1.0\text{mA}$	-	-	0.5	V
\overline{ERR} Turn On Impedance		$R_{DS,(ON),ERR}$	Refer to the “Test Circuit for Electrical Characteristics”	200	300	500	Ω
Output Current 1		I_{OUT1}	$V_{DS} = 0.8\text{V}$ $R_{ext} = 1.8\text{k}\Omega$	-	324	-	mA
Current Skew 1		dI_{OUT}/I_{OUT}	$I_{OL} = 324\text{mA}$ $V_{DS} = 0.8\text{V}$ $R_{ext} = 1.8\text{k}\Omega$	-	± 1	± 3	%
Output Current 2		I_{OUT2}	$V_{DS} = 0.6\text{V}$ $R_{ext} = 2.4\text{k}\Omega$	-	243	-	mA
Current Skew 2		dI_{OUT}/I_{OUT}	$I_{OL} = 243\text{mA}$ $V_{DS} = 0.6\text{V}$ $R_{ext} = 2.4\text{k}\Omega$	-	± 1	± 3	%
Regulation of Output Current vs. Sustaining Voltage		$\%/dV_{DS}$	V_{DS} within 1.0V and 3.0V	-	± 0.1	-	% / V
Regulation of Output Current vs. Supply Voltage		$\%/dV_{DD}$	V_{DD} within 4.5V and 5.5V	-	± 1	-	% / V
Pull-up Resistor		$R_{IN(up)}$	$\overline{OE}, \overline{QT}$	250	500	800	K Ω
Junction Temperature Threshold		T_x	When T_j approaches T_x and \overline{OUT} is shut off.	-	165	-	$^\circ\text{C}$
Supply Current	“OFF”	$I_{DD(off) 1}$	$R_{ext} = \text{Open}, \overline{OUT0} \sim \overline{OUT1} = \text{Off}$	-	5	9	mA
		$I_{DD(off) 2}$	$R_{ext} = 2.4\text{k}\Omega, \overline{OUT0} \sim \overline{OUT1} = \text{Off}$	-	6	10	
		$I_{DD(off) 3}$	$R_{ext} = 1.8\text{k}\Omega, \overline{OUT0} \sim \overline{OUT1} = \text{Off}$	-	8	12	
	“ON”	$I_{DD(on) 1}$	$R_{ext} = 2.4\text{k}\Omega, \overline{OUT0} \sim \overline{OUT1} = \text{On}$	-	6	10	
		$I_{DD(on) 2}$	$R_{ext} = 1.8\text{k}\Omega, \overline{OUT0} \sim \overline{OUT1} = \text{On}$	-	7	10	

Test Circuit for Electrical Characteristics

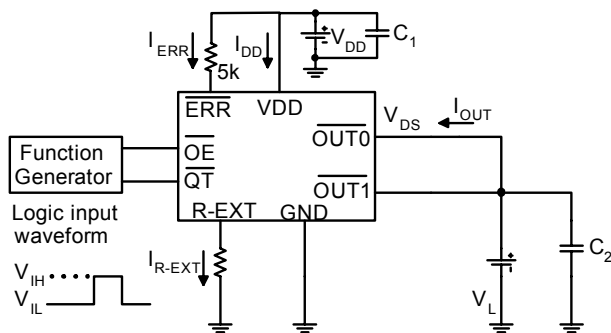

Figure 2

Switching Characteristics

Characteristic		Symbol	Condition	Min.	Typ.	Max.	Unit
Propagation Delay Time ("L" to "H")	$\overline{OE} - \overline{OUTn}$	t_{pLH}	$V_{DD} = 5.0\text{ V}$ $V_{DS} = 1.0\text{ V}$ $V_{IH} = V_{DD}$ $V_{IL} = \text{GND}$ $R_{ext} = 1630\Omega$ $(I_{OUTn} = 360\text{ mA})$ $V_L = 4.0\text{ V}$ $R_L = 8.684\Omega$ $C_L = 10\text{ pF}$	0.3	0.5	1	μs
Propagation Delay Time ("H" to "L")	$\overline{OE} - \overline{OUTn}$	t_{pHL}		0.3	0.5	1	μs
Pulse Width	\overline{OE}	$t_{w(OE)}$		1	-	-	μs
Output Rise Time of \overline{OUT} (turn off)		t_{or}		0.3	0.5	1	μs
Output Fall Time of \overline{OUT} (turn on)		t_{of}		0.3	0.5	1	μs

Test Circuit for Switching Characteristics

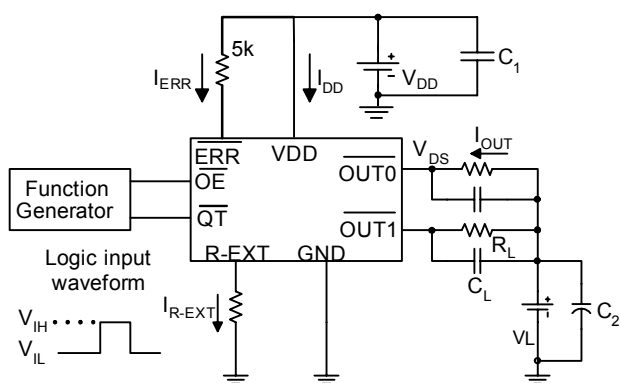
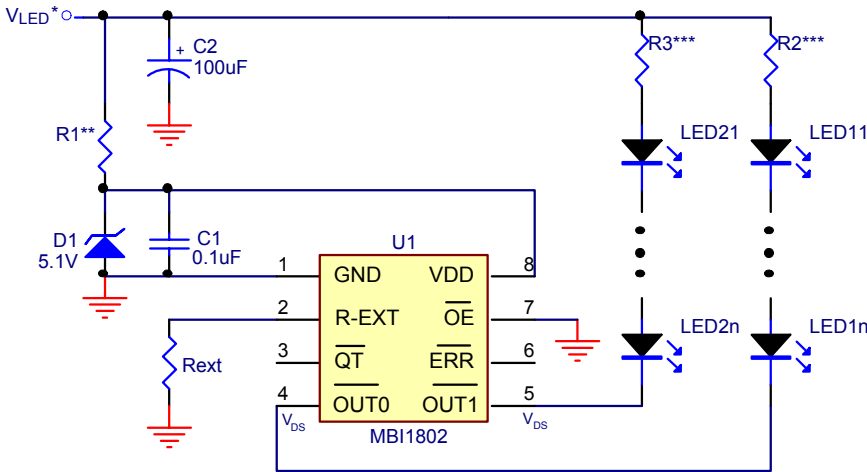

Figure 3

Application Information

Application Circuits

(a) MBI1802 application circuit, where V_{LED} and V_{DD} share a single voltage source.



* $V_{LED} > V_{DS} + V_{F,LED} \times n$; $V_{F,LED}$: Forward voltage of LED; n: LED count

** $R1 = (V_{LED} - 5.1V) / I_{DD}$; refer to Electrical Characteristics for I_{DD}

*** $R2 = R3 = [V_{LED} - V_{DS} - (V_{F,LED} \times n)] / I_{LED}$

(b) MBI1802 Application Circuit with dimming control by PWM signal, where V_{LED} and V_{DD} use voltage sources separately.

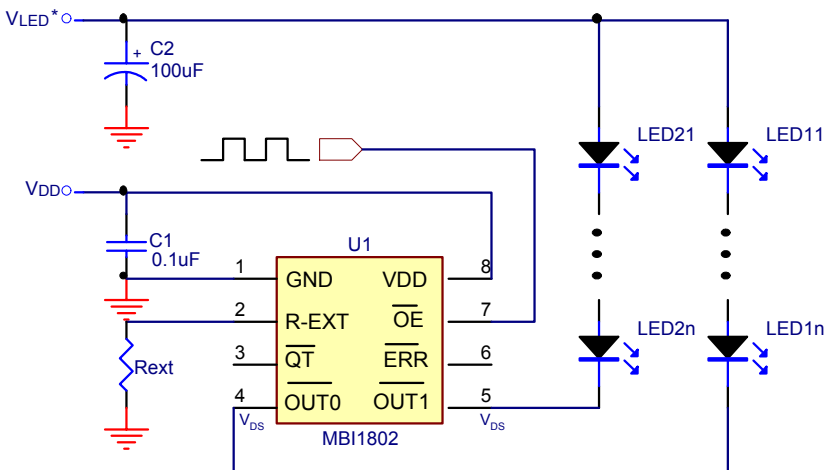

* $V_{LED} = V_{DS} + V_{F,LED} \times n$; $V_{F,LED}$: Forward voltage of LED; n: LED count

Figure 4

Constant Current

In LED lighting applications, MBI1802 provides nearly no variation in current from channel to channel and from IC to IC. This can be achieved by:

- 1) The maximum current variation between channels is less than $\pm 3\%$, and that between ICs is less than $\pm 6\%$.
- 2) In addition, the current characteristic of output stage is flat and users can refer to the figure as shown below. The output current can be kept constant regardless of the variations of LED forward voltages (V_F). This guarantees LED to be performed on the same brightness as user's specification.

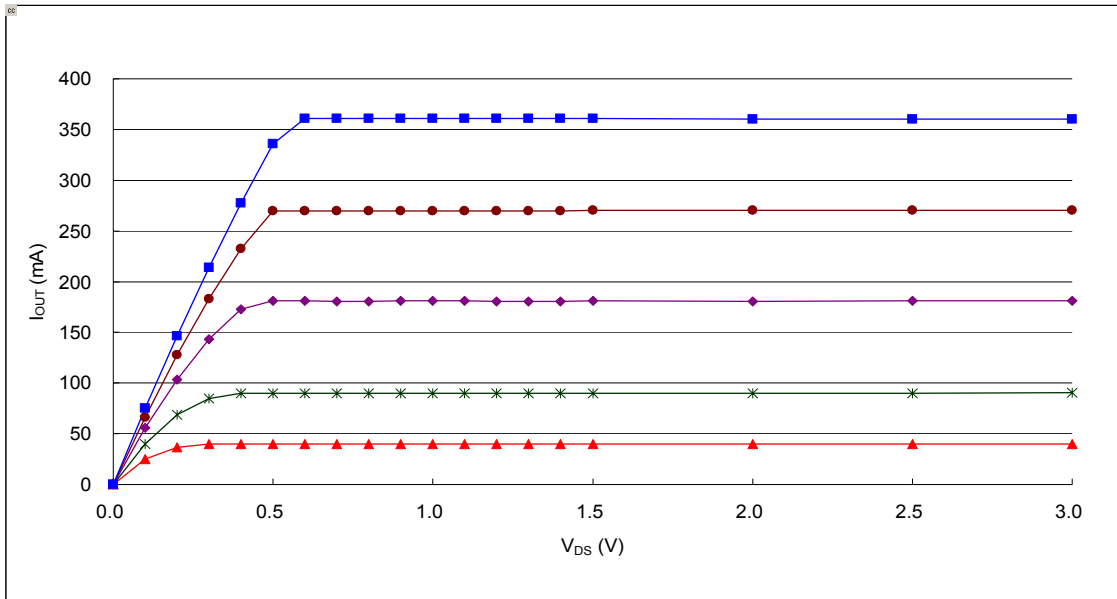

Figure 5

Setting Output Current

The output current of each channel (I_{OUT}) is set by an external resistor, R_{ext} . The relationship between I_{OUT} and R_{ext} is shown in the following figure.

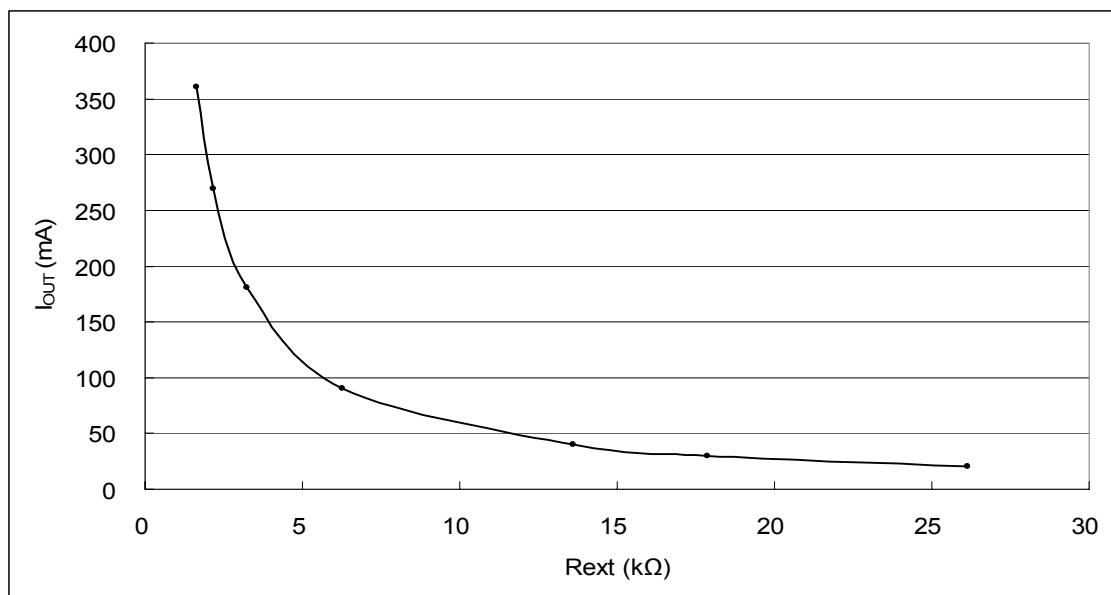

Figure 6

Also, the output current can be calculated from the equation:

$$V_{R-EXT} = 1.24V ;$$

$$R_{ext} = (V_{R-EXT} / I_{OUT}) \times 471 = (1.24V / I_{OUT}) \times 471,$$

$$I_{OUT} = (V_{R-EXT} / R_{ext}) \times 471 = (1.24V / R_{ext}) \times 471 \text{ within } \pm 6\% \text{ chip skew}$$

where R_{ext} is the resistance of the external resistor connected to R-EXT terminal and V_{R-EXT} is the voltage of R-EXT terminal. The magnitude of current (as a function of R_{ext}) is around 243mA at 2.4kΩ and 324mA at 1.8kΩ.

Soldering Process of "Pb-free & Green" Package Plating*

Macroblock has defined "Pb-Free & Green" to mean semiconductor products that are compatible with the current RoHS requirements and selected **100% pure tin (Sn)** to provide forward and backward compatibility with both the current industry-standard SnPb-based soldering processes and higher-temperature Pb-free processes. Pure tin is widely accepted by customers and suppliers of electronic devices in Europe, Asia and the US as the lead-free surface finish of choice to replace tin-lead. Also, it is backward compatible to standard 215°C to 240°C reflow processes which adopt tin/lead (SnPb) solder paste. However, in the whole Pb-free soldering processes and materials, 100% pure tin (Sn) will all require up to 260°C for proper soldering on boards, referring to J-STD-020C as shown below.

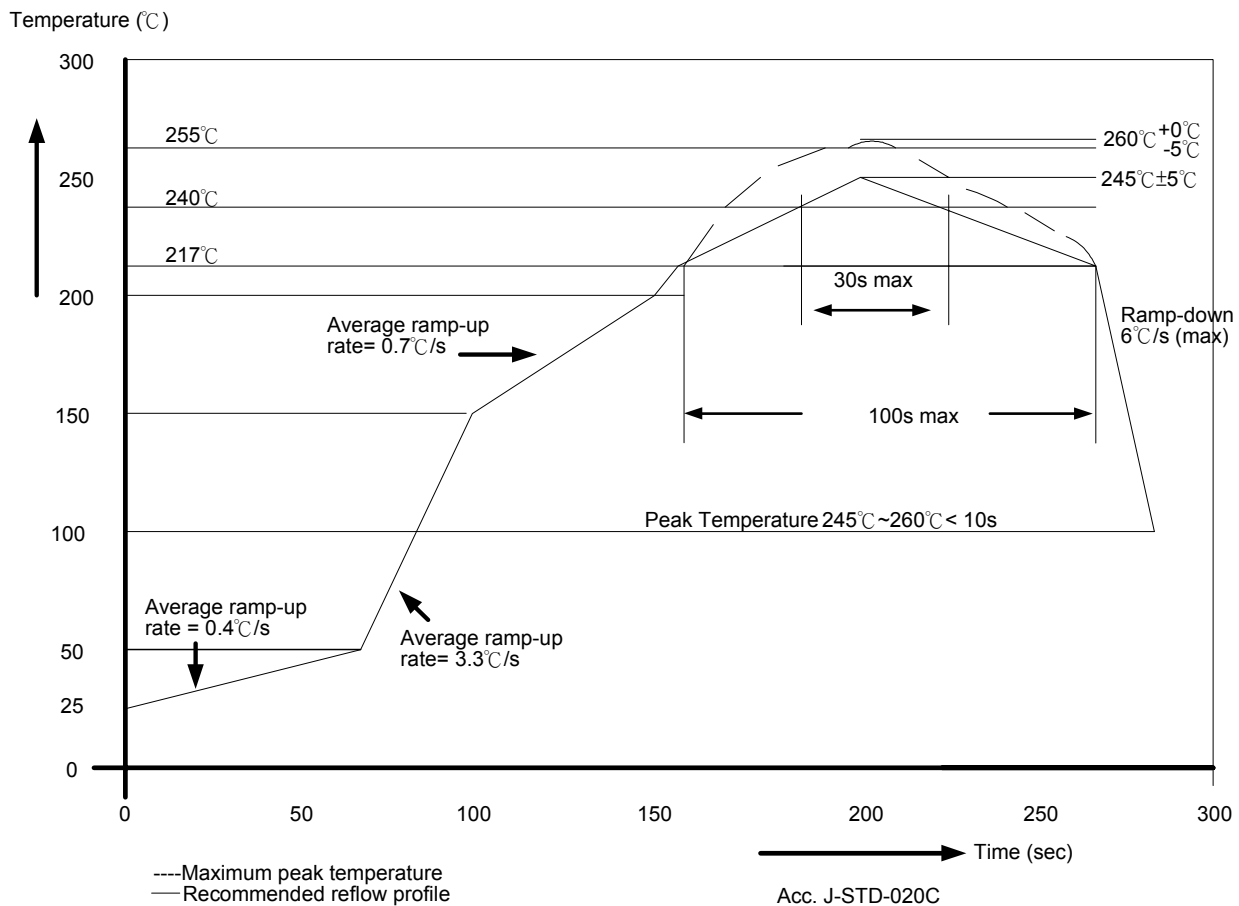

*Note: For details, please refer to Macroblock's "Policy on Pb-free & Green Package".

Package Power Dissipation (P_D)

The maximum power dissipation, P_{D(max)} = (T_{j,max} - T_a) / R_{th(j-a)}, decreases as the ambient temperature increases.

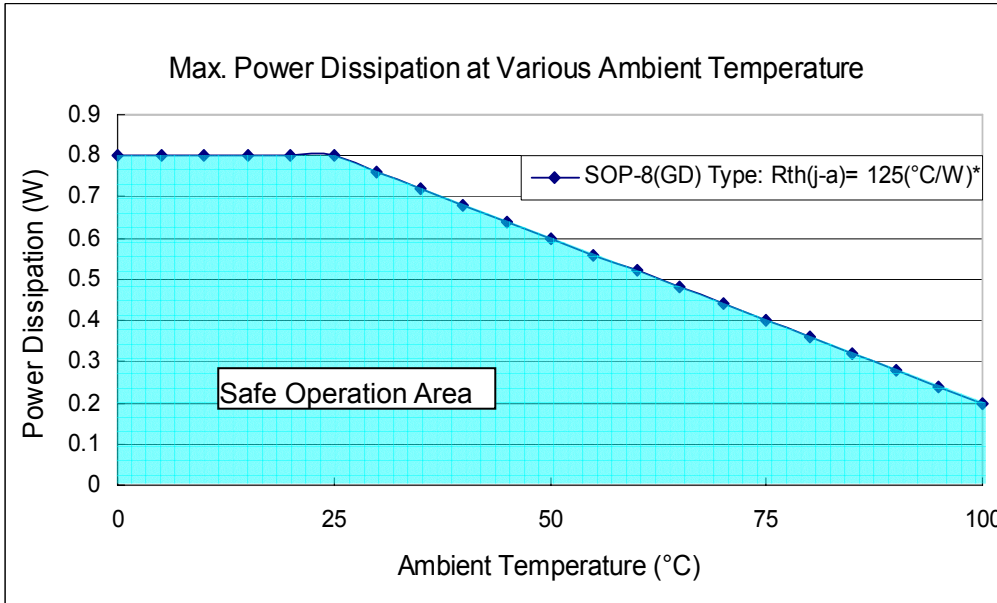

Figure 7

The maximum allowable package power dissipation is determined as P_{D(max)} = (T_{j,max} - T_a) / R_{th(j-a)}. When 2 output channels are turned on simultaneously, the actual package power dissipation is P_{D(act)} = (I_{DD} x V_{DD}) + (I_{OUT} x Duty x V_{DS} x 2). Therefore, to keep P_{D(act)} ≤ P_{D(max)}, the allowable maximum output current as a function of duty cycle is:

$$I_{OUT} = \{ [(T_j - T_a) / R_{th(j-a)}] - (I_{DD} \times V_{DD}) \} / V_{DS} / \text{Duty} / 2,$$

where T_j = 125°C;

Duty = t_{ON} / T;

t_{ON}: the time of LEDs turning on; T: OE signal period

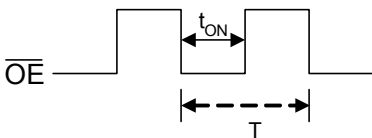

*Note: The empirical thermal resistor R_{th(j-a)} = 125 °C/W is based on the following structure.

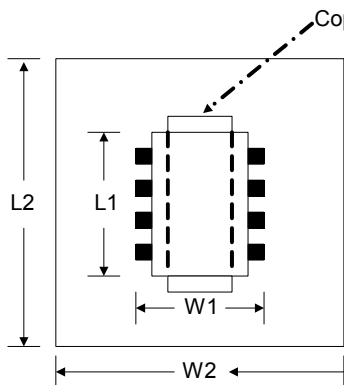

The PCB area L₂xW₂ is 4 times of the IC's area L₁xW₁.

The thickness of the PCB is 1.6mm, copper foil 1 Oz. The thermal pad on the IC's bottom has to be mounted on the copper foil.

TP Function (Thermal Protection)

When the junction temperature exceeds the threshold, T_x (165°C), TP function turns off the output current and the thermal error flag, \overline{ERR} , goes low simultaneously. As soon as the temperature is below 165°C, the output current will be turned on again. The on-state and off-state switch at a high frequency; thus, the blinking is imperceptible. However, the average output current is limited, and therefore, the driver is protected from being overheated.

Load Supply Voltage (V_{LED})

MBI1802 is designed to operate with adequate V_{DS} to achieve constant current. V_{DS} together with I_{OUT} should not exceed the package power dissipation limit, $P_{D(max)}$.

As in Figure 8, $V_{DS} = V_{LED} - V_F$, and V_{LED} is the load supply voltage. $P_{D(act)}$ will be greater than $P_{D(max)}$, if V_{DS} drops too much voltage on the driver. In this case, it is recommended to use the lowest possible supply voltage or to set an external voltage reducer, V_{DROP} .

A voltage reducer lets $V_{DS} = (V_{LED} - V_F) - V_{DROP}$.

Resistors can be used in the applications as shown in Figure 8.

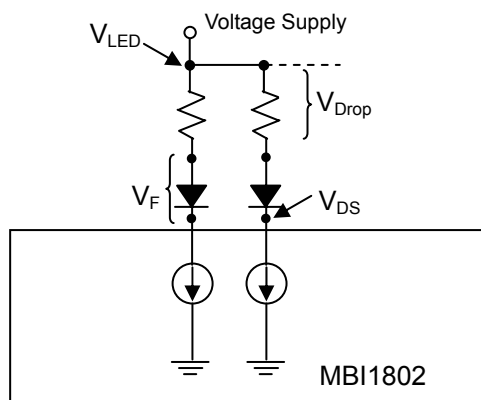
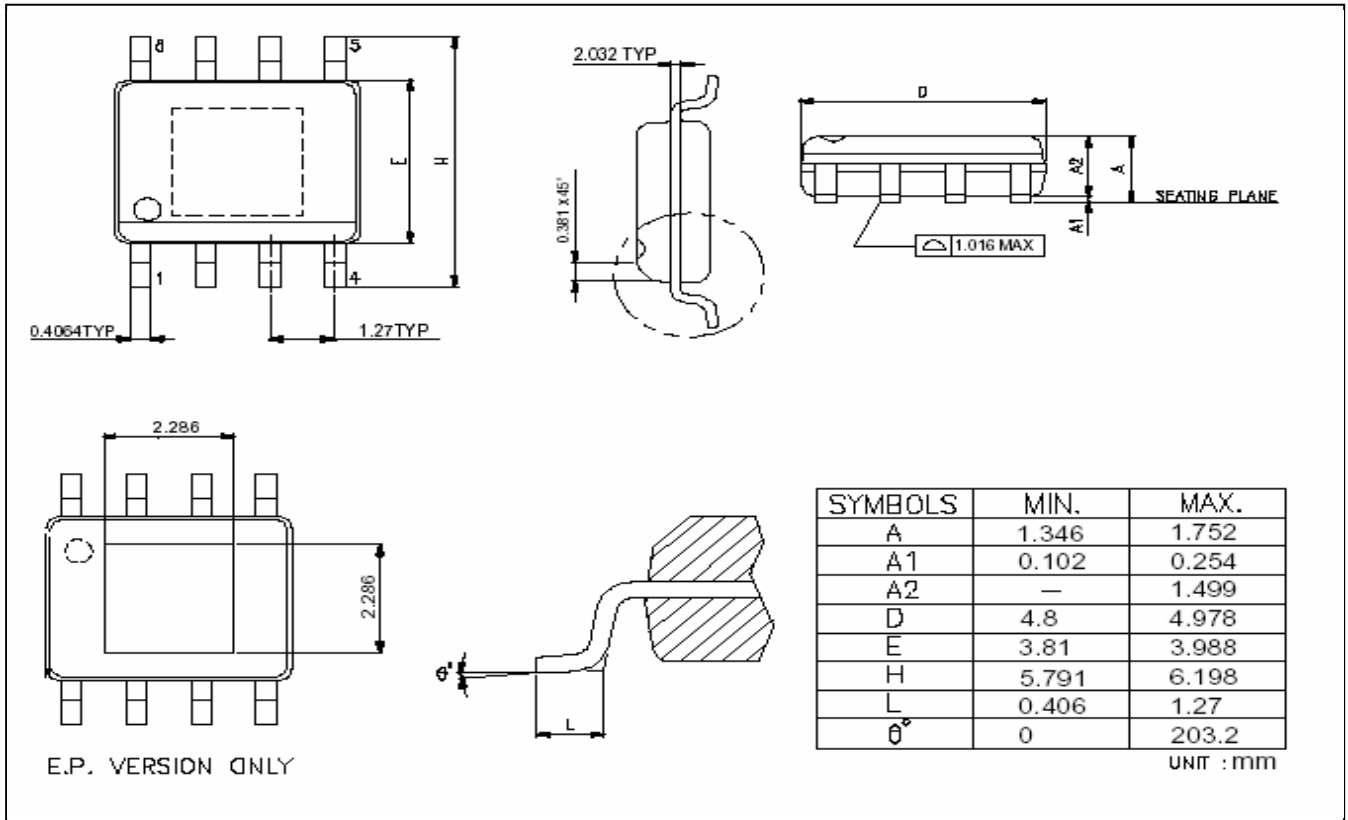

Figure 8

Outline Drawing



MBI1802GD Outline Drawing

Note: The unit for the outline drawing is mm.

Product Top-mark Information

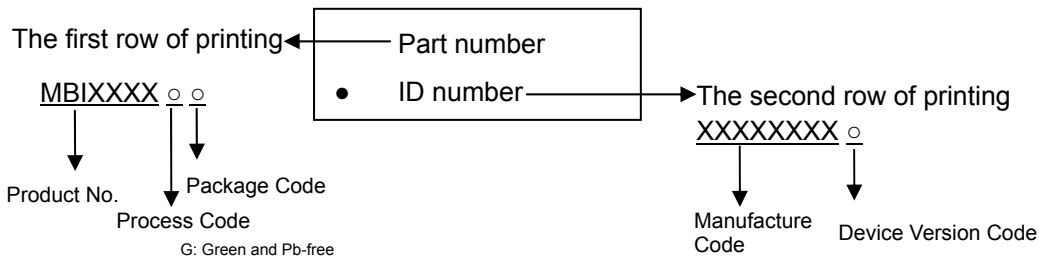

Product Revision History

Datasheet Version	Device Version Code
V1.00	Not defined
V1.01	A
V1.02	B
V1.03	B

Product Ordering Information

Part Number	Package Type	Weight (g)
MBI1802GD	SOP8-150-1.27	0.07

Disclaimer

Macroblock reserves the right to make changes, corrections, modifications, and improvements to their products and documents or discontinue any product or service without notice. Customers are advised to consult their sales representative for the latest product information before ordering. All products are sold subject to the terms and conditions supplied at the time of order acknowledgement, including those pertaining to warranty, patent infringement, and limitation of liability.

Macroblock's products are not designed to be used as components in device intended to support or sustain life or in military applications. Use of Macroblock's products in components intended for surgical implant into the body, or other applications in which failure of Macroblock's products could create a situation where personal death or injury may occur, is not authorized without the express written approval of the President of Macroblock. Macroblock will not be held liable for any damages or claims resulting from the use of its products in medical and military applications.

All text, images, logos and information contained on this document is the intellectual property of Macroblock. Unauthorized reproduction, duplication, extraction, use or disclosure of the above mentioned intellectual property will be deemed as infringement.